

PEGS

CONTENTS

PEGS	75
PEG ADAPTER CHART	77
FLOORBOARDS	82
SPLINED ADAPTER CHART	83
SHIFT & BRAKE COVERS	86
HIGHWAY/CRUISE PEGS & MOUNTS	88
HIGHWAY/CRUISE ADJUSTABLE PEGS	90
ADJUSTABLE PASSENGER PEGS/ FLOORBOARDS	96
MALE MOUNT PEGS	98



FLAMIN' PEGS Patent Pending

Flames add class & timeless design to your bike. Coordinate these pegs with our ISO-Flame Grips for a torchin' hot look! Motorcycle specific adapter required, page 77.

4417 | Flamin' Pegs without Adapter (pr) | \$89.99

Replacement Components:

4413	Flamin' Pegs Replacement Rubber Pads (4 pieces)	\$18.99
4447	Replacement "Curb Feelers" (pr)	\$9.99



Peg Adapters Found on Page 77!



FLAMIN' SWITCHBLADE PEGS

U.S. Patent # 6,893,038

We've added a flamin' new style to our comfortable switchblade peg. The flip-out heel rest makes a huge difference on those long rides. The Flamin' Switchblade makes a great addition to our Flamin' Pegs & ISO-Flame Grips. Motorcycle specific adapter required, page 77.

Note: Flip out arm designed to be a heel rest.

4412 | Flamin' Switchblade Pegs without Adapter (pr) | \$139.99

Replacement Components:

4413	Flamin' Switchblade Replacement Rubber Pads (4 pieces)	\$18.99
4447	Replacement "Curb Feelers" (pr)	\$9.99



PEGS AT-A-GLANCE

pegs . pegs . pegs . pegs . pegs

PEG QUICK REFERENCE

Küryakyn Pegs & their dimensions

Note: Length dimensions shown are approximately 5/8" longer than original peg length to accommodate Footpeg Adapter.

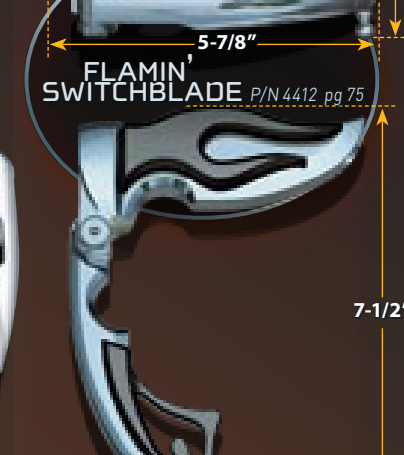
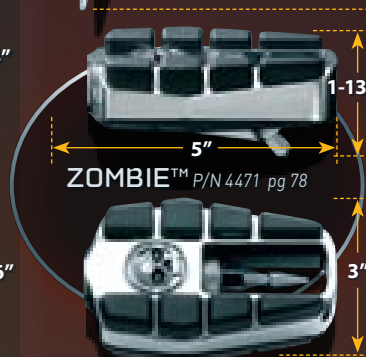
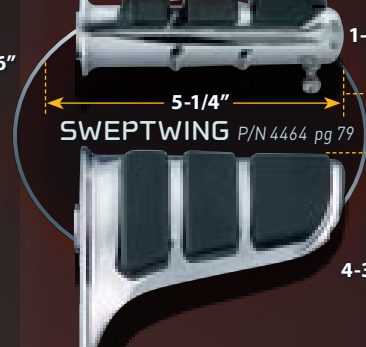
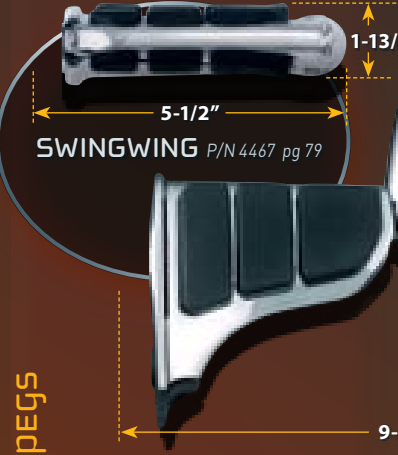
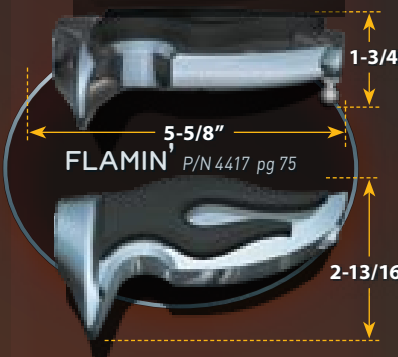
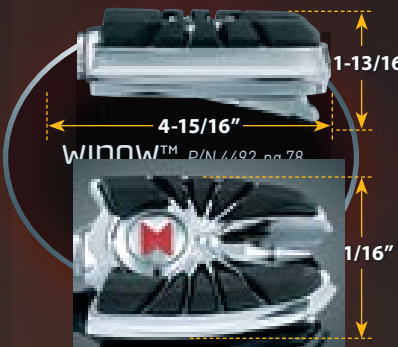
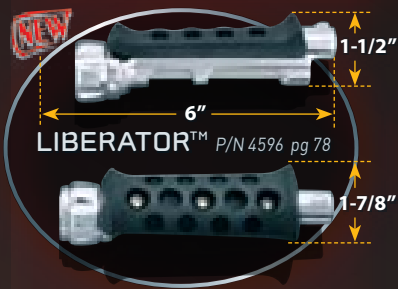

Note: Length dimensions shown on all pegs are approximately 5/8" longer than original peg length to accommodate Footpeg Adapter.

peg ADAPTERS

Küryakyn Footpegs are a 2-part system for convenience & easy installation. Simply select the Footpegs you desire & the appropriate motorcycle specific Adapter for your bike. The new serrated Adapters bite right into your footpegs for a secure attachment, so make sure they are at the desired angle before you tighten them down. This convenient 2-part system also allows you to change your pegs without purchasing new adapters. Have a new bike? Simply switch your pegs by purchasing new Adapters.

Note: Adapter fitments are for stock OEM peg mounts.

FOOTPEGS & ADAPTERS FIT TOGETHER AS SHOWN



New Serrated Ends Lock Into Pegs for Extra Hold!

SELECT THE ADAPTERS YOU NEED...

Find the part number for the adapter that corresponds to your motorcycle's front or rear location.

All Adapters Are \$21.99 (pr) (ex. 8805 \$24.99 (pr))

Cruiser Model	Year	Front	Rear
Triumph			
Thunderbird	'95-'03	8840	8840
Thunderbird Sport	'98-'00, '03	8840	8840
Adventurer	'96-'01	8840	8840
Legend	'99-'01	8840	8840
Bonneville & BonT100	'01-'08	None	8840
Bonneville America	'02-'08	8840	8840
Speedmaster	'03-'08	8840	8840

Cruiser Model	Year	Front	Rear
Victory			
Hammer	All	8805	8805
Vegas, 8-Ball, Jackpot	All	8805	8805
Kingpin*	All	None	8805*

Note: Motorcycle specific adapters only work with stock OEM peg mounts.

*Victory Kingpin-Only if using Accessory Peg Mounts from Victory.

Cruiser Model	Year	Front	Rear
Suzuki			
Marauder 1600/ Boulevard M95	'04-'06	8830	8831
Intruder 1500 LC/ Boulevard C90	'98-'08	None	8821
Intruder 1400/ Boulevard S83	'95-'08	8820	8821
Marauder 800	'97-'04	8820	8821
Boulevard C50	'05-'08	None	8823
Boulevard M50	'05-'08	7939	8823
Volusia 800	'01-'04	7939	8802
M109R	'06-'08	7939	8822

Cruiser Model	Year	Front	Rear
Yamaha			
V Star 1300	'07-'08	None	8809
V Star 1100	'99-'08	8810	8811
V Star 650	'98-'08	8810	8811
V-Max	All	8810	8811
Virago 1100	All	8810	8811
Virago 750	All	8810	8811
Road Star 1600/1700 (ex. Warrior)	'99-'08	None	8811
Road Star Warrior	'02-'08	8812	8809
Royal Star with OEM Rear Pegs	'96-'01	None	8811
Roadliner	'06-'08	None	8809
Stratoliner	'06-'08	None	8809
Raider	'08	8802	8809

Cruiser Model	Year	Front	Rear
Honda			
GL1800	'01-'08	7939	None
VTX1800C/F	'02-'08	8803	8802
VTX1800R/S/N/T	'02-'08	None	8802
GL1500	'88-'00	7946	None
Valkyrie (all)	'97-'04	7946	8802
VTX1300R/S	'03-'08	None	8802
VTX1300C	'03-'08	8803	8802
1100 Sabre	'00-'07	8803	8803
1100 Aero	'99-'02	None	8802
1100 Ace Tourer	'97-'03	7946	8802
1100 Spirit	'99-'07	8803	8803
1100 Shadow Ace	'95-'99	7946	8802
750 Spirit/Ace	'00-'08	8803	8802
750 Aero	'04-'08	8803	8802
750 Magna	'96-'04	8803	8802
600 VLX	'96-'07	8803	8802
600 VLX Deluxe	'96-'07	8803	8802

Cruiser Model	Year	Front	Rear
Kawasaki			
Vulcan 1600 Classic	'03-'08	None	8831
Vulcan 1500 Classic	'96-'08	None	8831
Vulcan 1500 A/B	'87-'99	8830	8831
Vulcan 1500 Drifter	'99-'05	None	8831
Vulcan 1500/1600 Mean Streak	'02-'08	8830	8831
Vulcan 800 Classic	'96-'05	8830	8831
Vulcan 800 Custom	'95-'05	8830	8831
Vulcan 2000 (All Models)	'04-'08	None	8831
Vulcan 900 Classic	'07-'08	None	8831
Vulcan 900 Custom	'07-'08	8830	8831



NEW

peg



LIBERATOR™ PEGS



Escape the tyranny of mundane pegs with Küryakyn Liberator Pegs! Barrel-shaped chrome bodies & perforated rubber pads, these pegs are ready to defend freedom everywhere. The Liberator Series includes footpegs & footpegs with stirrups.

4596	Liberator Pegs without Adapter (pr)	\$99.99
4598	Liberator Pegs & Stirrups without Adapter (pr)	\$159.99
4591	Liberator Pegs Replacement Rubber Pads (set)	\$15.99
4580	Stirrup Replacement Rubber Pad (ea)	\$7.99

Important: Requires Splined Adapter Mount, page 83.

WIDOW™ PEGS

Set your bike apart from the crowd. A full custom footpeg at a realistic price. Bet you'll get a bunch of compliments on these & your feet will love 'em, too. Motorcycle specific adapter required, page 77.

4492	Widow Pegs without Adapter (pr)	\$89.99
4493	Widow Pegs Replacement Rubber Pads (set)	\$12.99



KAISER PEGS

U.S. Patent # Des. 528,477

Add a little attitude to your bike with our Kaiser Pegs. The Maltese Cross always looks cool & coordinates great with Küryakyn Maltese Mirrors & ISO-Flame Grips with Maltese End Caps. Motorcycle specific adapter required, page 77.

4461	Kaiser Pegs without Adapter (pr)	\$89.99
4465	Kaiser Pegs Replacement Rubber Pads (set)	\$12.99
4490	Replacement "Curb Feelers" (pr)	\$9.99
4462	Replacement Maltese Cross Emblem (ea)	\$12.99



Peg Adapters Found on Page 77!

ZOMBIE™ PEGS

Skulls are where it's at! These skeletal pegs are sturdy & rugged. An ominous skull is nestled between the rubber pads with a sinister spire point filling the void. They look great by themselves or combined with any other products from our Zombie Series. Motorcycle specific adapter required, page 77.



4471	Zombie Pegs without Adapter (pr)	\$89.99
4472	Zombie Pegs Replacement Rubber Pads (set)	\$10.99
4474	Replacement "Curb Feelers" (set/4)	\$15.99
4473	Replacement Skull Emblem (ea)	\$13.99



TECH-TIPS

When installing any footpeg, footboard or highway peg combination, always verify all fasteners are tight & secure - even those you don't adjust. We also recommend periodically checking to make sure all fasteners remain tight.

SWINGWING PEGS

Patent Pending

Enormous numbers of people have asked us how they can stretch their legs a little without spending several hundred dollars for extended controls. Here's the answer... a convenient fold-forward, comfortable cruise peg that fastens in place of your stock peg & provides a secondary fold-out peg 3" forward.

Note: SwingWing Pegs are larger than stock. In passenger applications pegs may not fold up to stored position properly. Motorcycles with passenger peg mounts that angle to the rear also accentuate the non-folding application.

4467	SwingWing Pegs without Adapter (pr)	\$149.99
4468	SwingWing Pegs Replacement Rubber Pads (set)	\$19.99

Important: Requires Splined Adapter Mount, page 83.



ISO®-SWEPTWING PEGS

Streamline your bike with the sleek lines of the ISO-SweptWing Peg & get ready for flight. With traditional ISO design these beauties reduce vibration to give you that super comfortable footpeg you've been looking for. Coordinate them with our SwingWing Peg or Constellation Floorboard & flaunt that same sleek look throughout your whole bike. Motorcycle specific adapter required, page 77.

4464	ISO-SweptWing Pegs without Adapter (pr)	\$79.99
4469	ISO-SweptWing Replacement Rubbers (set)	\$16.99



DOMED END CAPS for Stiletto Footpegs & Stirrups

Put a slightly more subdued look on your Stiletto Pegs or Stirrups.

4483	Domed End Caps for Stiletto Stirrups (pr)	\$10.99
4484	Domed End Caps for Stiletto Pegs (pr)	\$11.99

STILETTO PEGS

The radical Stiletto Peg is designed for those who ride on the wild side. Motorcycle specific adapter required, page 77.

4476	Stiletto Pegs without Adapter (pr)	\$89.99
4490	Replacement "Curb Feelers" (pr)	\$9.99
4485	Stiletto Pegs Replacement Rubber Pads (6 pieces)	\$13.99



Add Stiletto Stirrups! See Page 81

SWITCHBLADE PEGS

U.S. Patent # 6,893,038 & Des. 506,707

The Switchblade Pegs are sleek, versatile, & supremely comfortable. In their standard retracted mode, they are a large surface area, rubber isolated footpeg. Deploy the concealed heelrest & you instantaneously have the fatigue fighting comfort of the famous Kuryakyn ISO-Stirrups. Although these pegs will work in any peg location, they are ideal for bikes with forward mounted controls or cruise pegs. Motorcycle specific adapter required, page 77.

4446	Switchblade Pegs without Adapter (pr)	\$119.99
4447	Replacement "Curb Feelers" (pr)	\$9.99
4448	Switchblade Pegs Replacement Rubber Pads (set)	\$17.99



Peg Adapters
Found on Page 77!



Pilot Peg
4419

Mini Pilot
4444

Retro Peg
4401

PEGS

Motorcycle specific adapter required, page 77.

7964	Small ISO-Pegs without Adapter (pr)	\$34.99
7965	Large ISO-Pegs without Adapter (pr)	\$36.99
4452	ISO-Wing without Adapter (pr)	\$89.99
7963	Dually ISO-Pegs without Adapter (pr) <small>U.S. Patent # Des. 405,393</small>	\$59.99
4419	Pilot Pegs without Adapter (pr) <small>Note: Updated parts available in Rubber Replacement Kit (P/N 4431)</small>	\$56.99
4401	Retro Pegs without Adapter (pr)	\$59.99
4444	Mini Pilot Pegs without Adapter (pr)	\$29.99

Note: ISO-Wings are not recommended for passenger applications on bikes with fixed rear peg mounts that angle to the rear. They cannot be folded to the stowed position properly.

REPLACEMENT RUBBER PADS & COMPONENTS

Even though our pegs are the finest available, after years of hard miles it might be necessary to replace worn out pads. Available in black only.

Constellation			Kaiser			Switchblade		
4459	Constellation Floorboard Set (10 pieces)	\$24.99	4465	Kaiser Peg Set (set)	\$12.99	4448	Switchblade Peg Set (10 pieces)	\$17.99
Flamin' & Flamin' Switchblade			4490	Replacement "Curb Feelers" (pr)	\$9.99	4447	Replacement "Curb Feelers" (pr)	\$9.99
4413	Flamin' Pegs Set (4 pieces)	\$18.99	4462	Replacement Maltese Cross Emblem (ea)	\$12.99	SwingWing		
ISO-			Liberator			4468	SwingWing Peg Set (12 pieces)	\$19.99
8009	Small Peg Set (8 pieces)	\$10.99	4591	Liberator Peg Set (2 pieces)	\$15.99	Widow		
8010	Large Peg Set (8 Pieces)	\$11.99	4580	Liberator Stirrup Set (1 piece)	\$7.99	4493	Widow Peg Set (4 pieces)	\$12.99
8023	Dually Peg Set (14 pieces)	\$16.99	Pilot			Zombie		
4454	Wing Set (8 pieces)	\$19.99	4431	Pilot Peg Set (8 pieces)	\$14.99	4472	Replacement Rubber Pads for Zombie Pegs (set)	\$10.99
4469	SweptWing Set (6 pieces)	\$16.99	4434	Mini Pilot Peg Set (2 pieces)	\$9.99	4474	Replacement "Curb Feelers" (set/4)	\$15.99
8011	Shift Peg Set for 8855/8856 (4 pieces)	\$6.29	Retro			4473	Replacement Skull Emblem (ea)	\$13.99
8082	Brake Pedal Pad Set for 8027 & 8857 (3 pieces)	\$9.99	4408	Retro Peg Set (4 pieces)	\$13.99	Stiletto		
8081	Brake Pedal Pad Set for 4025 (3 pieces)	\$9.99	Stiletto			4485	Stiletto Peg Set (6 pieces)	\$13.99
4543	Boards (8 pieces)	\$13.99	4486	Stiletto Stirrup Set (6 pieces)	\$10.99	4490	Replacement "Curb Feelers" (pr)	\$9.99





CHROME INSERTS FOR KURYAKYN ISO[®]-STIRRUPS

Finish off the back side of your stirrup with these chrome inserts.

8058 | Chrome ISO-Stirrup Inserts (pr) | \$14.99

REPLACEMENT ISO[®]-STIRRUP ARM

8078 | Stirrup Arm (Fits Right or Left) (ea) | \$24.99

8080 | Replacement Rubber Pads for ISO-Stirrups (pr) | \$9.99

8078

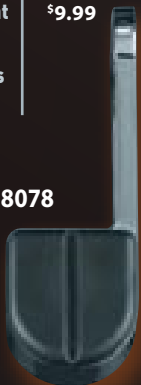

Pick A Peg, Add a Stirrup, Heelrest & Adapter



Large ISO-Peg



Retro Peg

ISO[®]-STIRRUPS For Metric Cruisers

The unbelievable comfort of stirrup heelrests is now available for Metric Cruisers. This adjustable-height heelrest allows footboard-like support to reduce fatigue on longer rides. Motorcycle specific adapter required, page 77.

4028 | ISO-Stirrups for Metric Cruisers (pr) | \$79.99

Note: Compatible with Large ISO-Pegs, Dually ISO-Pegs & Retro Pegs, SweptWing Pegs, & Flamin' Pegs, pages 75-80.

STILETTO STIRRUPS For Metric Cruisers

Upgrade the radical Stiletto Peg to long-haul comfort. For use with Stiletto Pegs only. Motorcycle specific adapter required, page 77.

4481 | Stiletto Stirrups (pr) | \$109.99

4486 | Replacement Rubber Pads for Stiletto Stirrups (set) | \$10.99

EXTENSIONS FOR GENUINE KURYAKYN ISO[®]-PEGs

For those applications where just a little bit longer footpeg would be nice! Two lengths are available.

Fits: Small ISO-Peg

8038 | 1" ISO-Peg Extensions (pr) | \$39.99

8039 | 1-1/2" ISO-Peg Extensions (pr) | \$39.99



4481



Liberator Peg Shown, sold separately



LIBERATOR[™] STIRRUPS

With matching style, add the comfort of stirrup heelrests to your Liberator Pegs. Splined Adapters required, page 83.

4599 | Liberator Stirrups without Pegs or Adapters (pr) | \$99.99

4580 | Liberator Stirrup Replacement Rubber Pad (ea) | \$7.99

Important Note: Only install with Kuryakyn Liberator Pegs (P/N 4596).

FLOORBOARDS

pegs . pegs . pegs . pegs . p

Passenger Boards
(P/N 4455) Now
Equipped with Splined
Mount to Positively
Lock In Place!

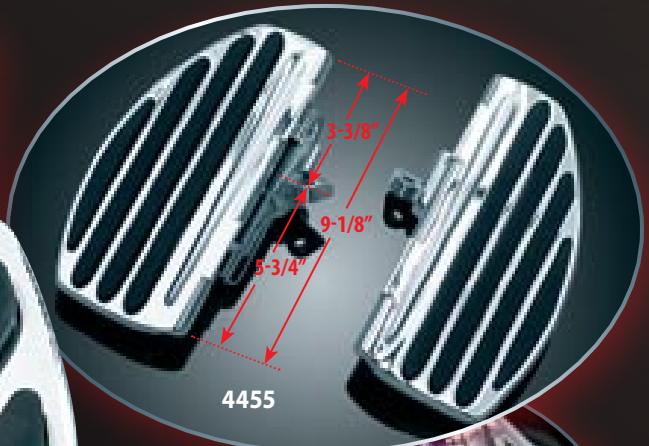

4455

Mount
in Either
Direction



4455

Replace your
Pegs with
Floorboards!



7916

ISO®-BOARDS for Metric Cruisers

Install a floorboard in place of a foot peg! These kits include our finely chromed ISO-Boards equipped with cushy, full length ISO rubber inserts & a cast bracket to connect the ISO-Board to the slip resistant splined adapter. We offer two options to suit your style. Please see illustration & dimensions above to determine style that best fits your application. Splined Adapters required & sold separately, page 83.

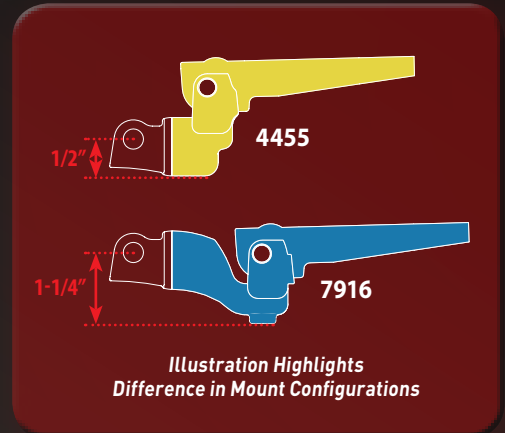



Illustration Highlights
Difference in Mount Configurations

7916	Driver or Passenger ISO-Boards for Metric Cruisers (pr)	\$199.99
4455	Passenger Only ISO-Boards & Mount Kit for Metric Cruisers (pr)	\$199.99 
4543	Replacement Rubber Pads for ISO-Boards (8 pieces)	\$13.99

Note: Passenger applications for P/N 7916 requires 1" clearance from bottom of footpeg mount & exhaust. Sits out 1" farther than stock peg.

Importance Notice: Adjustable shift & brake linkage is suggested for driver application. Placing these footboards on mounts intended for footpegs may prohibit them from folding up in the same manner as the stock peg. While the board may be rotated on the mount for a comfortable foot position, some angles may cause the board to contact other components on the bike before the board is folded up completely. Before ordering, be aware of components on the bike that may interfere with the placement of the floorboards.

CONSTELLATION BOARD FOOTPEG REPLACEMENT



Add style & comfort in minutes by simply replacing your pegs with these radically designed Constellation Boards! Mount directly to your standard peg location & gain adjustments in almost any direction. Choose the correct splined adapter for your desired mounting location & ride on!

- Floorboard measures 10" long by 4-1/2" wide. Extends back 4-3/4" from peg mount.
- Floorboards intended to fold at mounting block, not at standard footpeg mount.
- Both driver & passenger locations allow infinite adjustments within a 2" horizontal section. Floorboards rotate completely around splined adapter for optimal leg positioning.
- Choose between two positions when installing floorboards in the passenger location; the lower stock peg position or raised 1-1/8 inches for those shorter-legged riders.

Replace Your Passenger or Driver Footpegs!



4457

4457	Constellation Board Footpeg Replacement (pr)	\$199.99
4459	Replacement Rubber Pads for Constellation Floorboards (set)	\$24.99

Importance Notice: Adjustable shift & brake linkage is suggested for driver application. Placing these footboards on mounts intended for footpegs may prohibit them from folding up in the same manner as the stock peg. While the board may be rotated on the mount for a comfortable foot position, some angles may cause the board to contact other components on the bike before the board is folded up completely. Also, if the board is positioned so it will fold up as stock, the trailing end of the board may be in a position that could limit cornering clearance. Before ordering, be aware of components on the bike that may interfere with the placement of the floorboards.

SPLINED ADAPTER MOUNTS



Rear Splined Adapters Allow Both Folding & Rigid Mount In One! (P/N's 8818, 8825, & 8826)

Sold in Pairs

\$29.99



Küryakyn Footpegs & Floorboards for peg mounts are a 2-part system for convenience & easy installation. Simply select the Floorboards you desire & the appropriate motorcycle specific Splined Adapters for your bike. These Splined Adapters have teeth that match the footpegs or floorboards & allows the angle of the footrest to be set & locked in place. This convenient 2-part system also allows you to change your footrests without purchasing new splined adapters. Have a new bike? Simply switch your pegs or floorboards to a new bike by purchasing new Splined Adapters.

SPLINED ADAPTER for Driver & Passenger Cruise Pegs



Fits: Küryakyn footpeg mounts

8881 | Splined Male Mount Adapter (pr) | \$19.99

Cruiser Model	Year	Front	Rear
Honda			
VTX1800C/F	'02-'08	8815/8816*	8818
VTX1800R/S/N/T	'02-'08	None	8818
VTX1300R/S/T	'03-'08	None	8818
VTX1300C	'03-'08	8815	8818
1100 Spirit/Sabre	'00-'07	8815	8825
750 Aero/Spirit/Ace	'00-'08	8815	8818
750 Magna	'96-'04	8815	8818
600 VLX & Deluxe	'96-'07	8815	8818
Valkyrie	'97-'04	None	8826

* Splined Adapter for driver applications requiring P/N 8816 are intended for floorboard applications only.

Cruiser Model	Year	Front	Rear
Yamaha			
V Star 1300	'08	None	8825
V Star 1100	'99-'08	8814	8818
V Star 650	'98-'08	8814	8818
Virago 1100	All	8814	8818
Virago 750	All	8814	8818
Roadliner	'06-'08	None	8825
Stratoliner	'06-'08	None	8825
Road Star 1600/1700 (ex. Warrior)	'99-'08	None	8818
Road Star Warrior	'02-'08	8818	8825
Royal Star with OEM Rear Pegs	'96-'01	N/A	8818
Raider	'08	8818	8825

Cruiser Model	Year	Front	Rear
Suzuki			
Intruder 1500 LC/Boulevard C90	'98-'07	None	8818
Intruder 1400/Boulevard S83	'95-'07	None	8818
Boulevard C50	'05-'08	None	8818
Boulevard M50	'05-'08	8808	8818
Volusia/Marauder 800	'94-'04	8808	8818
M109R	'06-'08	8808	None

Note: Adapters for stock OEM Peg Mounts.

Cruiser Model	Year	Front	Rear
Kawasaki			
Vulcan 1500 A/B	'87-'99	8813	8826
Vulcan 1500/1600 & Mean Streak	'96-'08	8813	8826
Vulcan 800 Classic	'96-'05	8813	8826
Vulcan 800 Custom	'95-'05	8813	8826
Vulcan 2000	'04-'08	None	8826
Vulcan 900 Custom	'07-'08	8813	8826
Vulcan 900 Classic	'07-'08	None	8826



FLAMED FLOORBOARD COVERS

Patent Pending

Create a flamin' custom chrome look to your stock floorboards. These covers mount right over your stock floorboards to make a larger, more comfortable foot position without reducing your cornering clearance. Coordinate these covers with other Küryakyn Flame accessories to add a hot look to your entire bike!

7025	<p>Flamed Floorboard Covers (pr) Fits: Yamaha: '99-'08 V Star 1100 Classic, '07-'08 V Star 1300, '99-'08 Road Star 1600/1700 (ex. Warrior) Kawasaki: '03-'08 Vulcan 1600 Classic/Nomad, '04-'08 Vulcan 2000, Vulcan 800/1500 including Classic/Nomad/Drifter, '07-'08 Vulcan 900 Classic Suzuki: '05-'08 Boulevard C90/C50 Victory: All Victory OEM Driver Floorboards (ex. Vision) Note: This product only installs over OEM Factory Floorboards & are larger than OEM Floorboards. Kawasaki Vulcan 900 Classic & Suzuki C90/C50 will not accept Küryakyn Heel Shift Cover (P/N 4029). Will not install on Vulcan 2000 with Kawasaki Engine Guards.</p>	\$149.99
7026	<p>Flamed Floorboard Covers for Honda (pr) Fits: Honda: All VTX1800 & VTX1300 (Retro, etc) Note: This product only installs over OEM Factory Floorboards.</p>	\$149.99

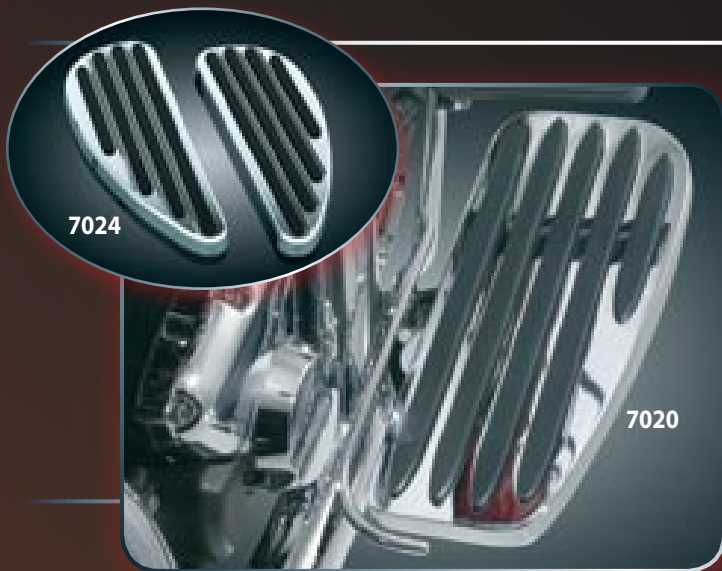
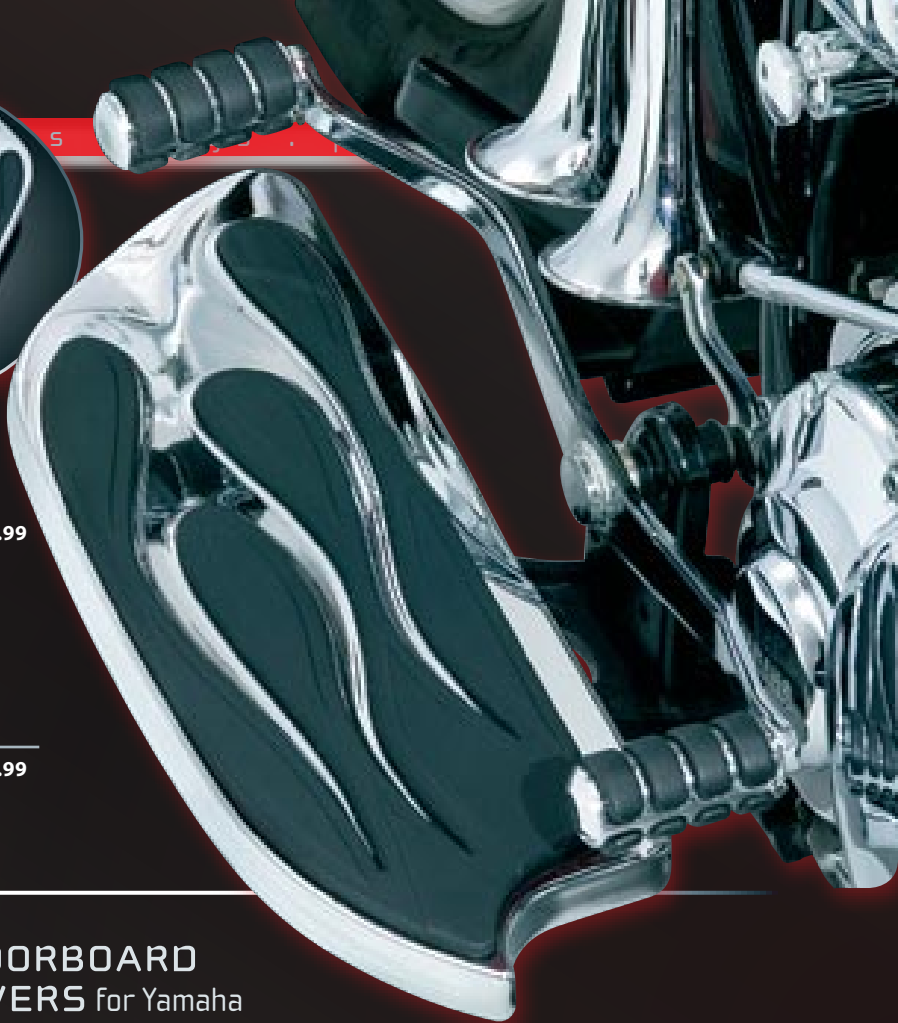

FLOORBOARD COVERS for Yamaha

U.S. Patent # Des. 544,410

Dress up those drab stock rider (driver) boards with these finely chromed covers. Rubber inserts add comfort & give your boots a better grip. To install, just peel off the stock rubber layer, pop the cover into place, & screw the cover onto the stock board from the bottom.

7020	<p>Floorboard Covers for Yamaha (pr) Fits: '99-'08 V Star 1100 Classic & all '99-'08 Road Star 1600/1700 (ex. Warrior) & '07-'08 V Star 1300</p>	\$129.99
7024	<p>Floorboard Covers for Yamaha (pr) Fits: All Roadliner & Stratoliner Models with OEM floorboards</p>	\$129.99

FLOORBOARD COVERS for VTX & Kawasaki

Patent Pending

Simple to install with a huge impact. These Floorboard Covers really make a difference to your foot rest area.

7021	<p>Floorboard Covers for VTX (pr) Fits: '02-'08 VTX1800 with factory Floorboards (Retro, etc) '03-'08 VTX1300 with factory floorboards (Retro, etc.)</p>	\$129.99
7022	<p>Floorboard Covers for Kawasaki (pr) Fits: '03-'08 Vulcan 1600, '04-'08 Vulcan 2000, Vulcan 900 Classic with OEM floorboards</p>	\$129.99
7023	<p>Floorboard Covers for Kawasaki (pr) Fits: All Floorboard Model Kawasaki Vulcan 800/1500's, including Classic, Nomad & Drifter</p>	\$129.99



SHIFTER PIVOT COVER for VTX

On a finely finished bike like the VTX, you don't want an ugly weld showing on an otherwise decent shift lever. In a heartbeat you can cure this with our creamy smooth chrome cover.

Fits: '02-'08 VTX1800 Retro/S/N/T

4046	<p>Shifter Pivot Cover (ea)</p>	\$24.99
------	--	---------

ENGINE GUARDS

ERGO ENGINE GUARD

For VTX U.S. Patent # 6,969,083

Bringing innovative design to the limits, our Ergo Engine Guard combines a stylish engine guard with built-in highway pegs. These highway pegs can be used in the stock inner position or flipped out for an additional foot position option.

For those of you with driver pegs, add the optional Forward Control Relocation Kit (P/N 4590) & stretch out your legs for additional comfort. Relocation Kit moves foot controls forward 2".

4585	Ergo Engine Guard for VTX1800 (set) Fits: All VTX1800 Models	\$299.99
4586	Foot Control Relocation Kit for use with Ergo Engine Guard (set) Fits: All VTX1800C/F with Ergo Engine Guard	\$79.99
4587	Ergo Engine Guard for VTX1300 (set) Fits: All VTX1300 Models	\$329.99

Note: Not compatible with Cruise Peg Mounts (P/N's 4518 & 4519).



ERGO GUARD LIGHT MOUNTING BRACKETS

With this simple bracket kit, you can easily install Kuryakyn Silver Bullets (or any other light using a 5/16" mounting screw). The kit includes two brackets & hardware to secure them to the existing holes beneath the foot rest area.

Recommended options for Silver Bullets include P/Ns 2303 or 2319 - See page 53 for more details.

2284 | Ergo Guard Light Mounting Brackets (pr) | **\$39.99**

Note: If adding Silver Bullets to function as driving lights, we highly recommend using our Wiring & Relay Kit (P/N 2328) page 55.

UNIVERSAL KICKSTAND EXTENSION

Reach your kickstand with ease with this Universal Kickstand Extension. Clamps great onto kickstands 1/2" to 3/4" diameter & extends out either 2-7/8" or 4-3/8". Some suggested top Models to use this new product on are:

Honda: All VTX1300/1800

Kawasaki: Vulcan 1500/1600/2000

Suzuki: C50/C90

Yamaha: All Road Star, all V Star 650/1100/1300 Models

Fits: Universal kickstands with 1/2" to 3/4" diameter

7108 | Universal Kickstand Extension (ea) | **\$39.99**



ENGINE GUARD with Fixed Footrests for VTX



Enjoy stretched out cruising comfort & a degree of engine protection without obtrusive looks. We've honed this popular cruise peg/engine guard combo into a simpler product by using a new static peg design. The legendary comfort & clean low profile styling is untouched. Enjoy the evolution of this great system at a new lower price!

4581	Engine Guard with Footpegs for All VTX1800 Models (set)	\$249.99
4582	Engine Guard with Footpegs for All VTX1300 Models (set)	\$249.99

Note: Not compatible with Cruise Peg Mounts (P/N's 4518 & 4519).



Rendering Shown- final design may vary.

Built-In Footpegs!



SHIFT & BRAKE COVERS . p e g s . p e



4029

Brake Pad on Shadow Sabre 1100

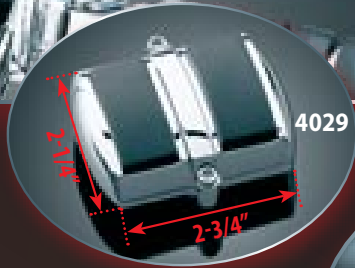

8851

ROUND SHIFT PEG COVERS

This round rubber-lined chrome shift peg is now offered in three sizes to accommodate almost any round shift peg.

SHIFT & BRAKE PEDAL PAD COVERS

A slick little chrome & rubber clam-shell cover that replaces the stock rubber pad on brake or heel shift pedals.

4029 | Shift & Brake Pedal Cover (ea) | \$29.99

Honda: '96-'07 VLX600 (Brake Pedal)
'01-'08 750 Spirit (Brake Pedal)
'96-'04 750 Magna (Brake Pedal)
'02-'07 1100 Sabre (Brake Pedal)
'97-'99 1100 ACE (Brake Pedal)
'96-'07 1100 Spirit (Brake Pedal)
'04-'08 Shadow 750 Aero (Brake Pedal)

Kawasaki: '86-'06 Vulcan 750 (Brake Pedal)
'03-'08 Vulcan 1600 (Heel Shift)
'96-'08 Vulcan 1500 (Heel Shift)
'07-'08 Vulcan 900 Classic (Heel Shift)
'07-'08 Vulcan 900 Custom (Brake Pedal)

Suzuki: '01-'04 Volusia 800 (Brake Pedal)
'02-'08 Marauder 800/Boulevard M50 (Brake Pedal)
'98-'08 Intruder 1500LC/Boulevard C90 (Heel Shift)
'05-'08 Boulevard C50 (Heel Shift)
Note: Shift position may need to be adjusted to accept P/N 4029 Heel Shift.

Yamaha: '98-'08 V Star 650 Custom (Brake Pedal)
'99-'08 V Star 1100 Custom (Brake Pedal)
'98-'00 V Star 650 Classic (Brake Pedal)

4045 | Brake Pedal Cover (ea) | \$29.99

Kawasaki: '02-'08 Mean Streak Models

Suzuki: '04-'06 Marauder 1600/Boulevard M95 Models

Yamaha: '06-'08 Roadliner & Stratoliner, '07-'08 V Star 1300 Models, '01-'08 V Star 650 Classic, '00-'08 V Star 1100 Classic, & '96-'08 Royal Star with 2" by 3-1/8" Rubber Pad

4037 | Brake Pedal Cover (ea) | \$26.99

Victory: '99-'03 V92C Models
All V92DC Models
All V92TC Models

8851 | Round Shift Peg Cover (ea) | \$18.99

Kawasaki: Vulcan 1500 (Toe Only, Heel P/N 4029),
Vulcan 1600 (Toe Only, Heel P/N 4029)
Vulcan 2000 (Toe & Heel)
Vulcan 900 Custom (Toe Only)
Vulcan 900 Classic (Toe Only, Heel P/N 4029)
Mean Streak (Toe Only)

Suzuki: '98-'04 Intruder 1500C, '05-'08 Boulevard C90 & C50 (Toe Only, Heel P/N 4029)

Note: Shift peg position adjustment required for installation of 4029 Heel Shift Cover on C50

Yamaha: Royal Star & Venture (Heel & Toe)
'07-'08 Road Star (Toe Only)
'99-'06 Road Star (Heel & Toe) ('06 Heel Only if OEM Style Round with Rubber)
'06-'08 Roadliner & Stratoliner (Toe Only),
'02-'08 Road Star Warrior (Toe Shift & Brake Pad),
'99-'08 V Star 1100 Classic (Toe Only, Heel P/N 4034),
'01-'08 V Star 650 Classic (Toe Only, Heel P/N 4034),
'07-'08 V Star 1300 (Toe Only, Heel P/N 4034)
'08 Raider (Toe Shift & Brake Pad)

Note: Will also fit most any other application with round shift pegs approximately 2-9/16" long & 9/16" in diameter.

8852 | Round Shift Peg Cover (ea) | \$18.99

Honda: All '02-'08 VTX1800 & '03-'08 VTX1300C

Note: Will also fit most any other application with round shift pegs approximately 2-5/8" long & 9/16" in diameter.

8853 | Round Shift Peg Cover (ea) | \$18.99

Victory: All Models (ex. Kingpin)

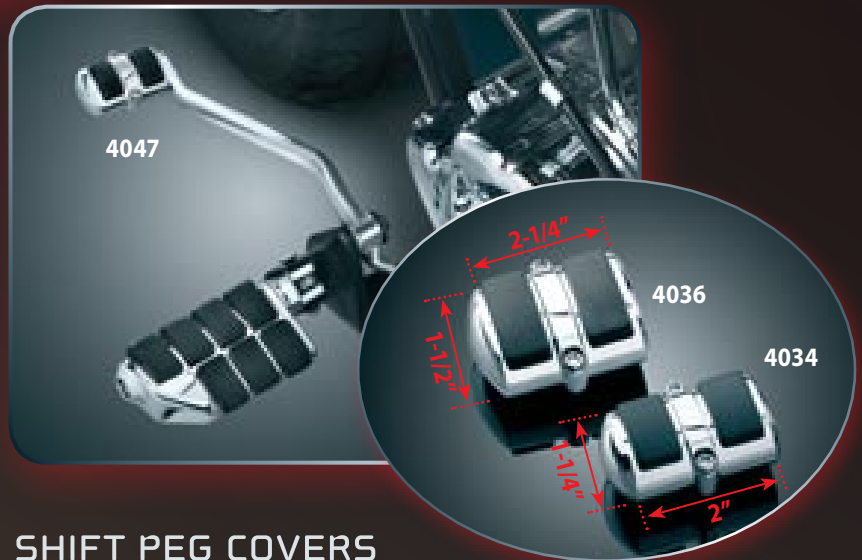

SHIFT PEG COVERS

Our classy chrome & rubber "clam-shell" design Shift Peg Covers replace the drab rubber OEM shift pegs pads. Simple hassle-free installation.

4034 | Shift Peg Cover (ea) | \$18.99

Yamaha: '98-'00 V Star 650 Classic (Toe), '98-'08 V Star 650 Custom (Toe), '01-'08 V Star 650 Classic (Heel Only, Toe P/N 8851), '99-'08 V Star 1100 Classic (Heel only, Toe P/N 8851), '99-'08 V Star 1100 Custom (Toe), '07-'08 V Star 1300 (Heel Only, Toe P/N 8851)

Note: Will also fit most any application with an oval shift peg with a width of 5/8" or less.

4036 | Shift Peg Cover (ea) | \$18.99

Honda: '04-'08 Shadow Aero 750

Note: Will also fit most any application with an oval shift peg with a width of 5/8" or slightly larger.

4047 | Shift Peg Cover (ea) | \$18.99

Honda: '03-'08 VTX1300 Retro/S/T (Heel & Toe)



ISO[®]-SHIFT & BRAKE PEGS
for Victory

These classy looking pegs replace the stock rubber shift or brake pegs on Victory Kingpin Models. Installs in minutes.

Fits: '04-'08 Victory Kingpin Models

8855	ISO-Shift or Brake Peg - Short (ea)	\$17.99
8856	ISO-Shift or Brake Peg - Long (ea)	\$19.99

BRAKE PEDAL COVER
for Yamaha Road Star 1600/1700

Add the smooth lines of this chromed brake pedal to finish off the lines of your Road Star. This clamshell design installs in minutes & shows a noticeable difference from the plain stock rubber look. Add Kuryakyn's Floorboard Covers (P/N 7020) & Shift Peg Cover (P/N 8851) to really transform the look of your foot controls.

Fits: All '99-'08 Road Star 1600/1700 Models (ex. Warrior)

8858	Brake Pedal Cover (ea)	\$29.99
-------------	-------------------------------	----------------

BRAKE PEDAL PAD for VTX Retro

Here is a gorgeous chrome & rubber brake pedal pad for all the VTX Retro Models. With the clam-shell design, installation takes only a couple minutes.

Fits: '03-'08 VTX1300 Retro/S/T & '02-'08 VTX1800 Retro/S/N/T Models

8849	Brake Pedal Cover (ea)	\$29.99
-------------	-------------------------------	----------------



BRAKE PEDAL COVER
for Vulcan

These hot looking covers add a custom touch to a Vulcan in minutes. Rich chrome & black rubber finish encapsulates the existing pieces - a breeze to install!

Fits: All Vulcan 1500 & '03-'04 Vulcan 1600 Classic Models ('05-'08 Vulcan 1600 use P/N 8857)

8850	Chrome Brake Pedal Cover (ea)	\$29.99
-------------	--------------------------------------	----------------



BRAKE PEDAL PAD

This is one of our most popular parts that can be easily adapted for use on several Cruisers. Simply drill one hole in your existing rear brake pedal.

8857	Brake Pedal Pad (ea) Fits: Kawasaki: '96-'08 Vulcan 1500, '05-'08 Vulcan 1600 Classic, all Vulcan 2000 & '07-'08 Vulcan 900 Classic Suzuki: '05-'08 Boulevard C50 & '98-'04 Intruder 1500LC Yamaha: '99-'08 Road Star	\$29.99
8082	Replacement Rubber Pads (set/3)	\$9.99



ISO[®]-BRAKE PEDAL PAD

The ISO-Brake Pedal Pad covers the raw unfinished end of your brake pedal. Beautiful chrome with rubber inserts for a non-slip surface.

Fits: '88-'00 GL1500 & all Valkyrie Models (ex. Rune)

4025	ISO-Brake Pedal Pad (ea)	\$29.99
8081	Replacement Rubber Pads (set)	\$9.99

QUICK REFERENCE
Shift & Brake Fitment Chart

A quick reference for a few Shift & Brake Cover fitments. See additional motorcycle specific applications for Honda, Kawasaki, Suzuki, Yamaha & Victory on pages 86-87.
(Confirm motorcycle fitment with matching P/N)

Cruiser Model	Toe Shifter	Heel Shifter	Brake Pedal
Kawasaki			
Vulcan 2000	8851	8851	8857
'05-'08 Vulcan 1600	8851	4029	8857
'03-'04 Vulcan 1600	8851	4029	8850, 8857
Vulcan 1500	8851	4029	8850, 8857
Vulcan 900 Custom	8851	None	4029
Vulcan 900 Classic	8851	4029	8857
Suzuki			
Boulevard C50	8851	4029	8857
Boulevard C90	8851	4029	None

Cruiser Model	Toe Shifter	Heel Shifter	Brake Pedal
Honda			
VTX1800R/S/N/T	8852	8852	8849
VTX1800C/F	8852	None	None
VTX1300R/S/T	4047	4047	8849
VTX1300C	8852	None	None
Aero 750	4036	None	4029
Yamaha			
'07-'08 Road Star 1700 (ex. Warrior)	8851	None	8858
'99-'06 Road Star 1600/1700 (ex. Warrior)	8851	8851	8858
Road Star Warrior	8851	None	8851
V Star 1300	8851	4034	4045
V Star 1100 Classic	8851	4034	4045
V Star 1100 Custom	4034	None	4029
'01-'08 V Star 650 Classic	8851	4034	4045
'98-'00 V Star 650 Classic	4034	None	4029
V Star 650 Custom	4034	None	4029
'06-'08 Roadliner	8851	None	4045
'06-'08 Stratoliner	8851	None	4045
'08 Raider	8851	None	8851

CRUISE MOUNTS

pegs . pegs



Mounts Directly to Your Floorboards for Yamaha, Kawasaki, & Suzuki!



4549

ADJUSTABLE CRUISE PEG MOUNTS for Floorboards

Add the comfort of cruise pegs & keep that clean simple style with these Adjustable Cruise Pegs Mounts. These little beauties bolt directly onto your floorboards & allow full adjustability for optional foot positions. Add any of Küryakyn's Male Mount Pegs & ride on!

4549	Adjustable Cruise Peg Mounts (pr) Fits: Yamaha: Road Star & V Star 1100 & 1300 with stock floorboards	\$169.99
4579	Adjustable Cruise Peg Mounts (pr) Fits: Kawasaki: All Vulcan 1600/2000 Models & all Vulcan 900 Classic with stock floorboards	\$169.99
4578	Adjustable Cruise Peg Mounts (pr) Fits: Suzuki: All '05-'08 Boulevard C50, all C90, all Intruder 1500 with stock floorboards	\$169.99

Note: Footpegs sold separately, page 98.



Works Great for Driver or Passenger

PEG MOUNTED CRUISE MOUNTS without Adapters

You wanted the simplest highway pegs & here they are. Directly mounting to your stock footpeg mounts, these offer a 6" adjustable arm to let you extend your legs where you want. Complete your kit with desired stylish Küryakyn pegs & splined adapter & ride on with added comfort.

Additional Products Required:

- Küryakyn Footpegs with Male Mount (pr), page 98.
- Küryakyn Footpegs without Male Mount (pr), pages 75-80.
- Motorcycle Specific Splined Adapter (pr), page 83.

7879 | Peg Mounted Cruise Mounts without Adapters (pr) | \$149.99

Note: Original foot position only accepts the following Küryakyn Pegs: Stiletto (P/N 4476), Switchblade (P/N 4446), Dually (P/N 7963), Large ISO (P/N 7965), Small ISO (P/N 7964), Retro (P/N 4401), Pilot (P/N 4419), ISO-Wing (P/N 4452), Sweptwing (P/N 4464), Flamin' (P/N 4417). Stock OEM pegs will not work with this product.

Now Uses Magnum Quick Clamp



4501

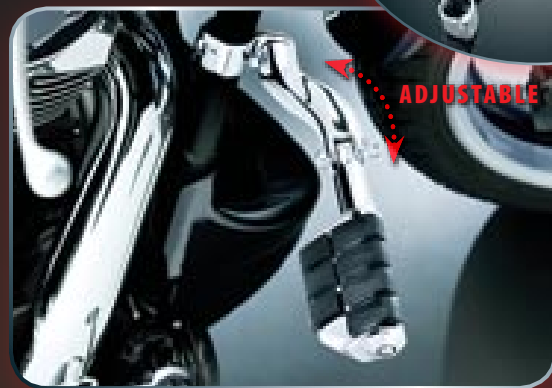

ADJUSTABLE CRUISE PEGS for Yamaha

U.S. Patent # Des. 405,393 & 411,440

Utilizing our easily installed 1-1/4" Magnum Quick Clamps & X-Tension Peg Mounts, alter your peg location to your liking. Comes equipped with our ever popular & durable Dually ISO-Peg. Ride on in style & comfort.

Fits: All '99-'08 Road Star 1600/1700, '02-'08 Road Star Warrior, '06-'08 Roadliner/Stratoliner, '99-'08 V Star 1100, V Star 650, '08 Raider requires 1-1/4" of available round space on both front frame tubes

4501 | Cruise Pegs for Yamaha (pr) | \$189.99

Note: Not suggested for use with full size engine guards.

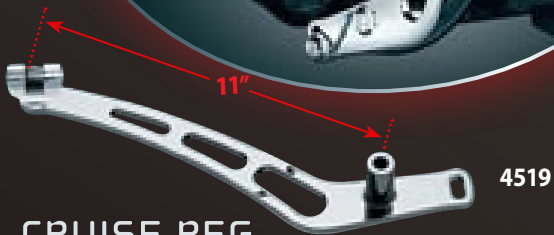

CRUISE PEG MOUNTS for VTX1300

Add cruise pegs without adding a bulky engine guard. These mount plates simply bolt onto the existing footboard or footpeg mounting bosses for a sturdy, comfortable "stretched out" setup that is also pleasing to the eye. Pegs sold separately, page 98.

Fits: '03-'08 VTX1300 Retro/S/T & '04-'08 VTX1300C Models

4519 | Cruise Peg Mounts for VTX1300 (pr) | \$149.99



MOVES FOOT CONTROLS 2" FORWARD

FORWARD CONTROL EXTENSION KIT for VTX1800

Move your driver pegs forward & stretch your legs to a comfortable position with our Forward Control Extension Kit. Designed to relocate your stock driver controls 2" forward, add that extra comfort to your ride by taking the extra bend out of your knees.

Fits: All VTX1800C/F with Front Peg Mounts

4590 | Forward Control Extension Kit for VTX1800 (set) | \$109.99

Note: Not compatible with Cruise Pegs (P/N 4518).

CRUISE PEGS for Shadow 1100

You will really enjoy pounding out the miles with these classy highway pegs. Offer many positions for your legs! Pegs sold separately, page 98.

Fits: '99-'07 Shadow Sabre 1100 & Spirit 1100 Models

4541 | Cruise Pegs for Shadow 1100 (pr) | \$149.99

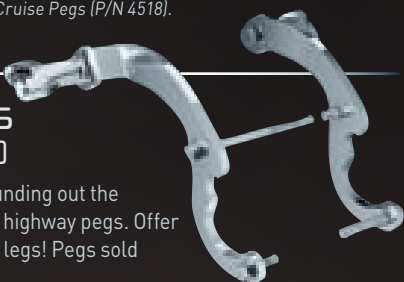

Stretch Out!

CRUISE PEG for VTX1800C/F

Here's the perfect solution for adding cruise pegs to the VTX1800C/F. This setup places the pegs in a comfortable "stretched out" location, without adding bulky engine guards to this sleek machine. These super clean mount plates simply bolt onto the existing forward controls for a sturdy, comfortable setup that is also pleasing to the eye. Pegs sold separately, page 98.

4518 | Cruise Peg Mounts (pr) | \$149.99
Fits: '02-'08 VTX1800C/F

Note: Does not work with Forward Control Extension Kit (P/N 4590).



CRUISE PEG MOUNTS for VTX Floorboards

Add our Cruise Peg Mounts to your stock driver floorboards & you have the best of both worlds. A comfy board & a cruise peg to stretch out the kinks on a long ride. You won't believe the difference. Pegs sold separately, page 98.

Fits: '02-'08 VTX1800R/S/N/T, '03-'08 VTX1300R/S/T Models

4540 | Cruise Peg Mounts for VTX with OEM Floorboards (pr) | \$149.99



ADJUSTABLE CRUISE PEGS . p e g s . p e g s . p e g s

TALL, SHORT, OR IN-BETWEEN?
WE HAVE YOU COVERED!



One Bike



Offset or Longhorn
Offset Highway Pegs



Comfortable Cruising
for Any Size Rider!

Kuryakyn Offset or Longhorn Offset Highway Pegs Allow Infinite Adjustment To Make Any Size Rider Comfortable!



Short



In-Between



Tall

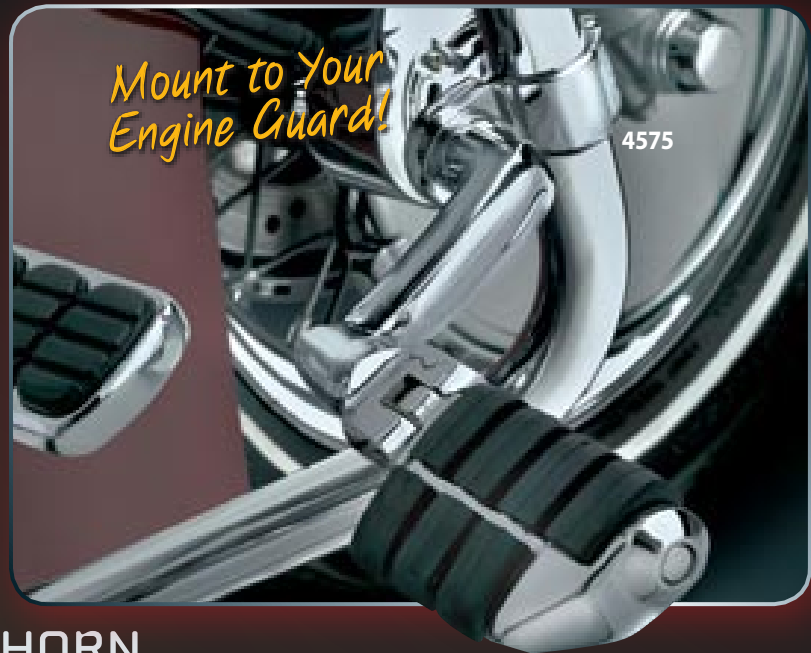

Mount to Your
Engine Guard!

4575

LONGHORN OFFSET DUALLY HIGHWAY PEGS

U.S. Patent # Des 411,440 & U.S. Patent # Des 405,393

The all-in-one answer for long-haul comfort. We combined our most popular highway peg components into one product that's attractive, adjustable, & easy to install.

4574	Longhorn Offset Dually with 1-1/2" Magnum Quick Clamp (pr)	\$149.99
4575	Longhorn Offset Dually with 1-1/4" Magnum Quick Clamp (pr)	\$149.99
7980	Longhorn Offset Dually with 1" Magnum Quick Clamp (pr)	\$149.99



FOOTPEGS WITH OFFSET MOUNTS & MAGNUM™ QUICK CLAMPS

U.S. Patent # Des. 411,440

These highway pegs utilize our unique offset mount to allow riders a range of adjustment not possible with other clamp-on style highway pegs. The offset can be rotated 360° in a 4" diameter circle to accommodate tall, short, or average height riders. These can be installed on any round tubing (frames or engine guards), but it is important to keep in mind that the footpeg itself will end up perpendicular to the bar to which it is mounted. If your engine guard is angled in such a way so that the peg will not be level once installed, look to our Right Angle Mounts (page 92) & male adapters with adjustable stop found on page 95.



7933
Great Highway Peg Options for Vulcan 1500/1600 - Uses 1.35" diameter clamp on front frame tube

Dually ISO®-Pegs with Offset Mounts & Clamps

U.S. Patent # Des. 405,393 & 411,440

7976	with 1" Diameter Clamps (pr)	\$139.99
7966	with 1-1/8" Diameter Clamps (pr)	\$139.99
7993	with 1-1/4" Diameter Clamps (pr)	\$139.99
7920	with 1.35" Diameter Clamps (pr)	\$139.99

Note: 1.35" clamps work great for Kawasaki front frame tubes.

Small ISO®-Pegs with Offset Mounts & Clamps

7998 | with 1-1/4" Diameter Clamps (pr) | \$119.99

Large ISO®-Pegs with Offset Mounts & Clamps

7999 | with 1-1/4" Diameter Clamps (pr) | \$129.99

7933 | with 1.35" Diameter Clamps (pr) | \$119.99

PILOT™ PEGS

with Offset Mounts & Clamps

4438	with 1" Diameter Clamps (pr)	\$139.99
4436	with 1-1/4" Diameter Clamps (pr)	\$139.99



Many Options for Ultimate Adjustability!

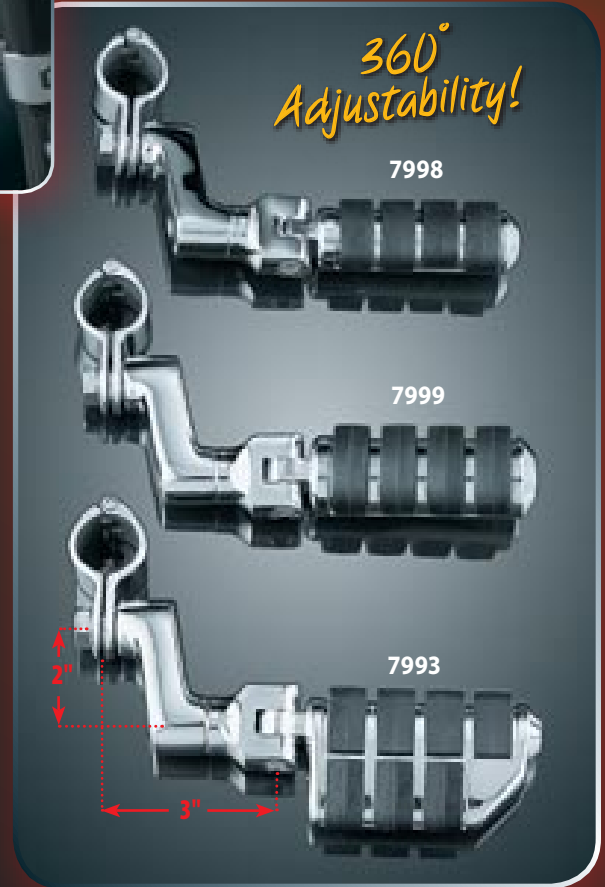

360° Adjustability!

7998

7999

7993

HELPFUL QUICK CLAMP SIZE SELECTION INFORMATION

- Barron Standard Engine Guards **1-1/4"**
- Cobra Standard Engine Guards **1-1/4"**
- Cobra Fatty Engine Guards **1-1/2"**
- Kawasaki Front Frame Down Tubes **1.35"**
- Valkyrie Curved Part of Engine Guard **1-1/8"**
- Yamaha Front Frame Down Tubes, All Road Star, V Star 1100/650, Roadliner, Stratoliner & Raider **1-1/4"**
- Yamaha Full Size/Full Loop Engine Guards **1-1/4"**
- Honda Full Size/Full Loop Engine Guards **1-1/4"**
- Victory Front Frame Down Tubes on '06 & Up Hammer, Kingpin, Jackpot, & 8ball **1-1/2"**

Note: To measure your tube size either use the tool on page 94 or tighten an adjustable wrench around the tube. Remove the wrench & measure the opening. Mounting Cruise Pegs off frame tubes requires 1-1/2" of strait open tube for clamping at equal height on both sides & approximately 3/8" of clearance around tube. Many mid 1990's smaller metric engine guards were a 1" tube.

LONGHORN OFFSET PEG MOUNT

This stylish peg mount provides 360° adjustability so it can be used to position the peg closer to the rider or further away. Its 3-1/4" arm gives an incredible 6-1/2" range of adjustment. Incorporating an innovative locking device this mount is guaranteed not to slip.

8016	Longhorn Offset Peg Mounts (pr) For use with Magnum Quick Clamps only, page 94.	\$69.99
7985	Longhorn Offset with 1" Clamp (pr) U.S. Patent # Des. 411,440	\$109.99
7986	Longhorn Offset with 1-1/4" Clamp (pr) U.S. Patent # Des. 411,440	\$109.99
4577	Longhorn Offset with 1-1/2" Clamp (pr) U.S. Patent # Des. 411,440	\$112.99

Note: Male Mount Pegs sold separately, page 98.

Accepts Any Male Mount Peg!
See Page 98

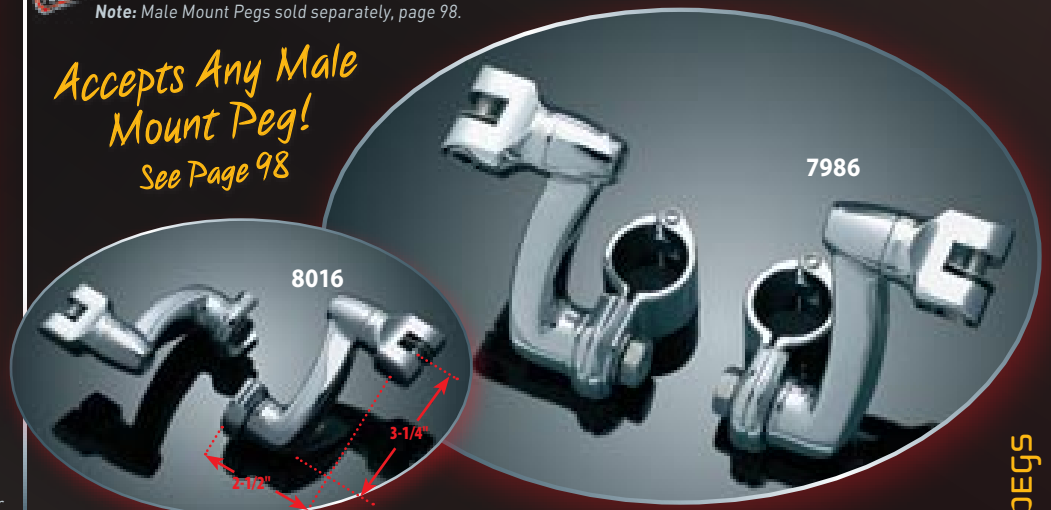

8016

7986



FOOTPEGS WITH RIGHT ANGLE MOUNTS & MAGNUM™ QUICK CLAMPS

U.S. Patent # Des. 411,440

This mount is the answer for motorcycles with an engine guard that does not allow the installation of a traditional style highway peg. Most highway pegs position the peg perpendicular to tubing to which they are mounted, thereby limiting their use on engine guards that run vertically. The Right Angle Mount overcomes this limitation & will allow you to position the peg horizontally regardless of the orientation of the engine guard.

Short Right Angle Mount with Clamps & Small ISO®-Pegs

4517 | with 1-1/4" Diameter Clamps (pr) | \$139.99

Short Right Angle Mount with Clamps & Dually ISO®-Pegs

U.S. Patent # Des. 405,393

4514 | with 1-1/4" Diameter Clamps (pr) | \$149.99

Long Right Angle Mount with Clamps & Small ISO®-Pegs

4507 | with 1" Diameter Clamps (pr) | \$139.99

Long Right Angle Mount with Clamps & Dually ISO®-Pegs

U.S. Patent # Des. 405,393

4509 | with 1" Diameter Clamps (pr) | \$149.99

CRUISE PEGS for Valkyrie (Including Interstate)

U.S. Patent # Des. 405,393 & 411,440

These Cruise Pegs feature 1-1/8" Magnum Quick Clamps. This allows placement on the front portion of the engine guards above or below the timing belt cover. The air scoops found on the Interstate Models do not interfere with this mounting system. Dually ISO-Pegs are included for supreme comfort.

4500 | ISO-Dually Cruise Pegs for Valkyrie (pr) | \$149.99

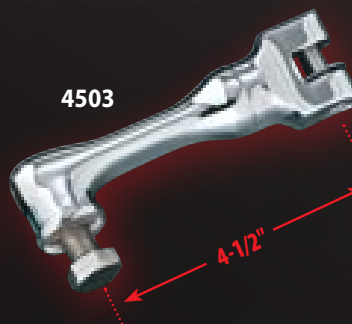

Works Great to Add Highway Pegs to Front Frame Downtubes Just Ahead of Your Motor (Requires 1/2" Clearance Around Tube)

RIGHT ANGLE MOUNTS

The Right Angle Footpeg Mount is our "contortionist." Most mounts position the peg perpendicular to the tubing on which it is mounted. Our Right Angle Mounts allow lots of flexibility in peg placements because they can be adjusted along two axes. Two lengths are available to cover many applications. This is the only setup we know of that permits cruise peg installation on engine guards that slope inward, outward or diagonally.

4503 | Long Right Angle Mounts (pr) | \$69.99

Note: Magnum Quick Clamps for Mounting, page 94.

Great Cruise Peg Option for Victory! Just Add Pegs (Page 98) & 1-1/2" Clamp (Page 94)

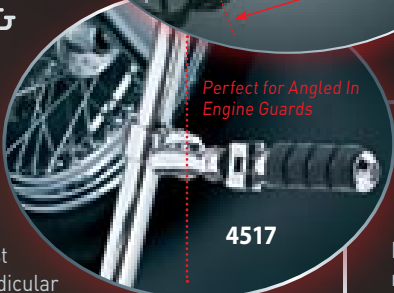

ERGO CRUISE PEGS for Valkyrie or GL1500

Ergonomically designed for maximum driver comfort, these mounts have an unbelievable range of adjustment for the tall, short or in-between rider. The articulated mounting bracket is made of highly polished stainless steel for extreme strength, great looks & simple installation. The 6" long chrome swing arm has an ingenious locking mechanism & is canted at a 6° angle which angles the pegs just the right amount for ideal comfort.

Fits: All Valkyrie (ex. Interstate or Rune) & '98-'00 GL1500 Models

4050	Ergo with Dually ISO-Pegs (pr) U.S. Patent #Des. 405,393	\$199.99
4040	Ergo with Lighted Cruise Boards (pr)	\$269.99
4041	Ergo with Un-Lighted Cruise Boards (pr)	\$259.99
4052	Ergo with ISO-Wings (pr)	\$209.99
4060	Short Replacement Ergo Arm, 4-1/2" (pr)	\$49.99
4061	Long Replacement Ergo Arm, 6" (pr)	\$49.99



FOOTPEGS WITH CLEVIS & MAGNUM QUICK CLAMPS

U.S. Patent # Des. 411,440

This is our most popular style of highway pegs. Using our patented Magnum Quick Clamp, they are a snap to install & provide long-haul comfort. There are several styles of footpegs to choose from with various sized clamps to accommodate most common engine guard diameters. They can be installed on any round tubing (frames or engine guards), but it is important to keep in mind that the footpeg itself will end up perpendicular to the bar to which it is mounted. If your engine guard is angled in such a way so that the peg will not be level once installed, look at our Right Angle Mounts (opposite page) or P/N 8008A, page 95.



4510

Small ISO®-Pegs with Clevis & Clamps

8030	with 1" Diameter Clamps (pr)	\$98.99
8032	with 1-1/4" Diameter Clamps (pr)	\$98.99

Large ISO®-Pegs with Clevis & Clamps

8031	with 1" Diameter Clamps (pr)	\$99.99
8033	with 1-1/4" Diameter Clamps (pr)	\$99.99

Dually ISO®-Pegs with Clevis & Clamps

U.S. Patent # Des. 405,393

4510	with 1" Diameter Clamps (pr)	\$129.99
7992	with 1-1/4" Diameter Clamps (pr)	\$129.99

Pilot™ Pegs with Clevis & Clamps

4435	with 1-1/4" Diameter Clamps (pr)	\$119.99
-------------	----------------------------------	----------

Switchblades with Clevis & Clamp

U.S. Patent # 6,893,038 & Des. 506,707

4443	with 1-1/4" Diameter Clamps (pr)	\$179.99
-------------	----------------------------------	----------

ISO-Wings with Clevis & Clamp

4451	with 1-1/4" Diameter Clamps (pr)	\$139.99
-------------	----------------------------------	----------



4451



4443



4435



All ISO-Stirrups Now Include Chrome Inserts

*Accepts Any Male Mount Peg!
See Page 98*



ISO®-STIRRUPS with Clevis & Clamp

U.S. Patent # Des 411,440 & U.S. Patent # Des. 338,643

This setup permits the use of the ISO-Stirrups on 1-1/4" engine guards.

8070	Small ISO-Peg with ISO-Stirrup & 1-1/4" Magnum Quick Clamp (pr)	\$159.99
8071	Large ISO-Peg with ISO-Stirrup & 1-1/4" Magnum Quick Clamp (pr)	\$159.99

UNIVERSAL CRUISE PEG MOUNTS

U.S. Patent # Des. 411,440

Although we can't understand why anyone wouldn't want to use our pegs, this setup will allow the use of any H-D or Kuryakyn Male Mount Pegs with our innovative Magnum Quick Clamps & Clevises for engine guard applications.

NEW 4573	1-1/2" Magnum Quick Clamp with Clevis (pr)	\$69.99
7944	1-1/4" Magnum Quick Clamp with Clevis (pr)	\$69.99
4576	1" Magnum Quick Clamp with Clevis (pr)	\$69.99

Note: Kuryakyn Male Mount Pegs, page 98.

Accepts Any Male Mount Peg!
See Page 98



MAGNUM™ QUICK CLAMPS

U.S. Patent # Des. 411,440

We've made a lot of friends with these! Stainless steel construction for superior strength & hinged design for fast simple installation. No more stripped bolt heads!

1000	1-1/4" I.D. Magnum Quick Clamp (pr)	\$39.99
1001	1-1/2" I.D. Magnum Quick Clamp (pr)	\$42.99
1002	1" I.D. Magnum Quick Clamp (pr)	\$42.99
7942	1.35" I.D. Magnum Quick Clamp (ea)	\$22.99
8073	1-1/4" I.D. Magnum Quick Clamp (ea)	\$22.99
7941	1-1/8" I.D. Magnum Quick Clamp (ea)	\$22.99
7940	1" I.D. Magnum Quick Clamp (ea)	\$22.99



Work Great for Mounting Cruise Pegs - Mounts to Frame Tubes or Engine Guards!



X-TENSIONS

Measuring 4-1/2" long with a 1-1/4" offset, X-Tensions allow the rider to slightly increase or decrease the reach to cruise pegs. They work great on Yamaha V Star 1100/650 or Road Stars with 1-1/4" clamps, with our Magnum Quick Clamps, or any custom applications. Requires Male Mount Pegs, page 98.

4515 | X-Tension (pr) | \$79.99

FOOTPEG MOUNTS & MOUNTING CLEVISES

All footpeg mounting clevises & footpeg mounts listed perform the same function. Your decision will be determined by the length required & the style you prefer.

7996	Offset Peg Mounts (pr)	\$49.99
8088	3-1/2" Long 1/2"-13 Thread (pr)	\$39.99
8061	Short Magnum Peg Mount with 1/2"-13 Thread (pr)	\$29.99
8015	Clevis with 1/2"-20 Thread (pr)	\$18.99

REPLACEMENT CLEVIS for Kuryakyn Offsets

Fits: Kuryakyn Conical Clevis Cruise Peg Applications, Offsets, Longhorns & Right Angle Mounts.

4568 | Serrated Replacement Clevis with Hardware (ea) | \$18.99



REPLACEMENT SCREWS & D-WASHERS

These mounts are found in virtually all of our highway peg assemblies.

4538	Replacement Clevis Screws with D-Washers (set)	\$4.99
4508	D-Washers (pr)	\$1.99



Check Your Tube Size to Ensure Accurate Clamp Selection

Cut out the chart below. To determine your tube size for proper clamp selection, start with 1" tube. Cut on the dotted lines & fold back the tab. Check if this opening fits around your tube. If it is too small keep moving down the lines until you reach the perfect fit.

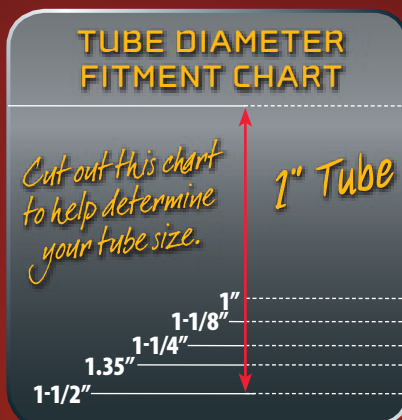

HELPFUL QUICK CLAMP SIZE SELECTION INFORMATION

- Barron Standard Engine Guards 1-1/4"
- Cobra Standard Engine Guards 1-1/4"
- Cobra Fatty Engine Guards 1-1/2"
- Kawasaki Front Frame Down Tubes 1.35"
- Valkyrie Curved Part of Engine Guard 1-1/8"
- Yamaha Front Frame Down Tubes, All Road Star, V Star 1100/650, Roadliner, Stratoliner & Raider 1-1/4"
- Yamaha Full Size/Full Loop Engine Guards 1-1/4"
- Honda Full Size/Full Loop Engine Guards 1-1/4"
- Victory Front Frame Down Tubes on '06 & Up Hammer, Kingpin, Jackpot, & 8ball 1-1/2"

Note: To measure your tube size either use the tool on page 94 or tighten an adjustable wrench around the tube. Remove the wrench & measure the opening. Mounting Cruise Pegs off frame tubes requires 1-1/2" of strait open tube for clamping at equal height on both sides & approximately 3/8" of clearance around tube. Many mid 1990's smaller Metric engine guards were a 1" tube.

ADJUSTABLE LOCKABLE OFFSETS

Adjust your cruise or highway pegs 2" or 4" forward, back, up or down for perfect comfort. With 360° of lockable adjustability, you can get your feet exactly where you want them. Simply mount the Adjustable Lockable Offset to any Küryakyn style footpeg mount, adjust the arm to desired foot position & lock them in place. Finish off with any Küryakyn Male Mount Pegs, page 98.

4556	2" Adjustable Lockable Offsets (pr)	\$79.99
4557	4" Adjustable Lockable Offsets (pr)	\$79.99

Adjust Your Cruise Pegs 2" or 4"

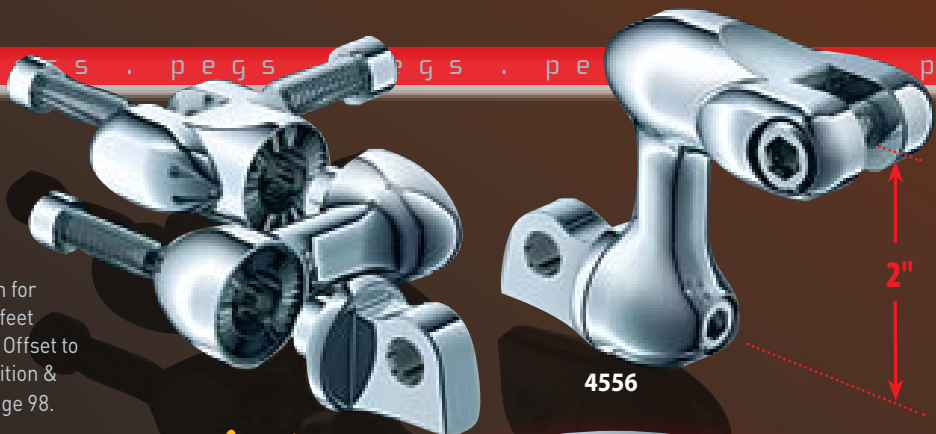

MALE MOUNT FOOTPEG EXTENSIONS

Made of machined steel & chrome-plated.

8063	1-1/2" Foot Peg Extensions (pr)	\$39.99
8064	2-1/2" Foot Peg Extensions (pr)	\$39.99

Note: For use as extension from Male Mount Clevis. Does not work with Metric OEM Peg Mounts.



Adjust Your Highway Peg Angle



MALE MOUNT LOCKABLE OFFSET

Move your cruise or highway pegs 2" to 4" inches forward, back, up, down, or any direction around your current mounts. These Lockable Offsets mount anywhere Küryakyn Male Mount Pegs install & accept any Küryakyn Pegs on pages 75-80.

Note: Male Mount Lockable Offset works with Cruise Peg Mounts.

7936	2" Lockable Offset (pr)	\$59.99
7937	4" Lockable Offset (pr)	\$59.99

MALE FOOTPEG ADAPTERS with Adjustable Stop

We have modified our standard H-D Type Male Footpeg Adapters with an adjustable stop which now makes it possible to install conventional clamp-on highway pegs on an engine guard that would normally cause the pegs to angle down toward the ground. We have added a small setscrew to the "heel" of the adapter. By adjusting the position of the setscrew, the angle of the footpeg can be adjusted. Best suited for use with Küryakyn Footpegs with Clevis & Magnum Quick Clamps (opposite page).

8008A	H-D Type Male Footpeg Adapters with Adjustable Stop (pr)	\$14.99
-------	--	---------

Note: For use with Küryakyn Cruise Peg Mounts or Mounting Clevises.



SERRATED MALE MOUNT for Cruise Pegs



8880	Serrated Male Mount (ea)	\$18.99
------	--------------------------	---------

PASSENGER COMFORT

pegs . pegs . pegs . p



Rotates 360 Degrees!



Accommodates Floorboards!

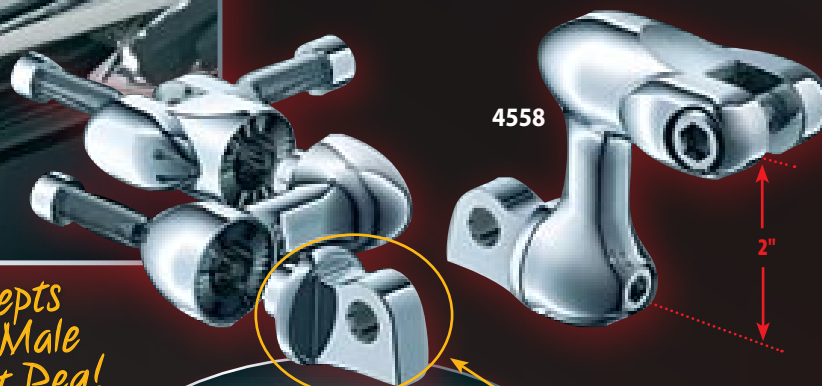

ADJUSTABLE LOCKABLE OFFSETS

A must-have for passengers! Complete circular rotation for 360° of comfort!

- Put your passenger pegs anywhere you want them
- Offered in two lengths – 2" or 4"
- Both male end & clevis can be rotated 360° & lock securely when tightened
- Investment cast & chrome plated for strength & durability

*Accepts Any Male Mount Peg!
See Page 98*

4558	2" Adjustable Lockable Offset without Male Mount (pr)	\$69.99
4559	4" Adjustable Lockable Offset without Male Mount (pr)	\$69.99

Note: P/N's 4558 & 4559 require Splined Adapters, page 83, & Male Mount Pegs, page 98.

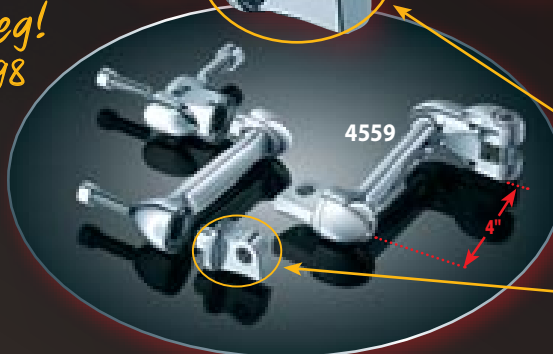

Splined Adapters Not Included



Swing Out Arm & Stretch Your Legs!

SWINGWING PEGS

for Passenger Comfort

Create A Floorboard-Like Feeling For Your Legs!

Give your passengers the comfort they desire. The SwingWing Peg provides a larger footpad for a fully supported feeling & has a swing-out footrest arm that provides a 3" forward & 3" wider secondary foot position. Let your passenger stretch out their legs & enjoy the ride! Requires Splined Adapter, page 83.

4467 | SwingWing Pegs Without Splined Adapter (pr) | \$149.99

Note: SwingWing Pegs are larger than stock. In passenger applications pegs may not fold up to stored position properly. Motorcycles with passenger peg mounts that angle to the rear also accentuate the non-folding application.

Note: Flipped out footrest arm is not intended to be used as a step when mounting or dismounting the motorcycle.



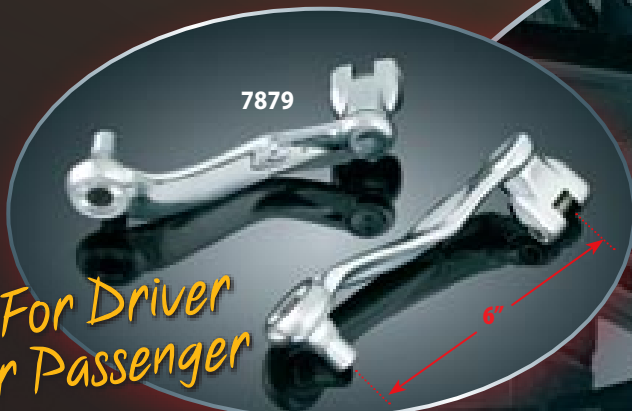

For Driver
or Passenger



Add a Second
Foot Position!

PEG MOUNTED CRUISE MOUNTS without Adapters

You wanted the simplest highway pegs & here they are. Directly mounting to your stock footpeg mounts, these offer a 6" adjustable arm to let you extend your legs where you want. Complete your kit with desired stylish Küryakyn pegs & splined adapter mount & ride on with added comfort.

Additional Products Required:

- Küryakyn Footpegs with Male Mount (pr), page 98.
- Küryakyn Footpegs without Male Mount (pr), pages 75-80.
- Motorcycle Specific Splined Adapter (pr), page 83.

7879 | Peg Mounted Cruise Mounts without Adapters (pr) | \$149.99

Note: Original foot position only accepts the following Küryakyn Pegs: Stiletto (P/N 4476), Switchblade (P/N 4446), Dually (P/N 7963), Large ISO (P/N 7965), Small ISO (P/N 7964), Retro (P/N 4401), Pilot (P/N 4419), ISO-Wing (P/N 4452), Sweptwing (P/N 4464), Flamin' (P/N 4417). Stock OEM pegs will not work with this product.
Note: Peg Mounted Cruise Mounts are larger than OEM pegs but mount on stock peg mounts. Due to clearance, this product may not fold up as OEM pegs do.

MALE MOUNT LOCKABLE OFFSETS

Adjust your Küryakyn passenger footpegs simply & easily. Splined mounting eliminates rotation & our conical mounts accept any Küryakyn Footpeg. Add your new offset in minutes.

8838	2" Splined Adapter Mount for Küryakyn Footpegs (pr)	\$49.99
8839	4" Splined Adapter Mount for Küryakyn Footpegs (pr)	\$49.99

Note: Footpegs may not fold in standard style due to clearance. Requires motorcycle specific Splined Adapter, page 83. Also requires Küryakyn Pegs, pages 75-80.

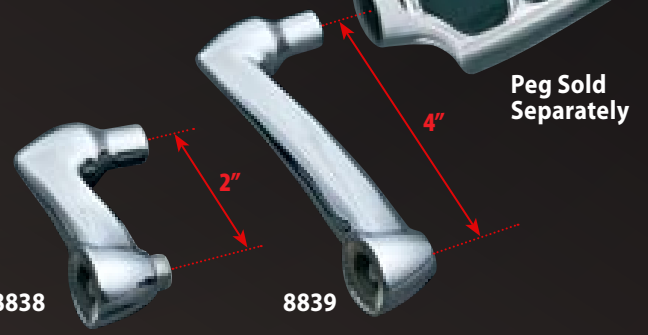

PASSENGER PEG MOUNTS for Road Star

You asked for them so we made 'em! Move your passenger footpeg mounts forward 3-1/2" & down 1-1/4" or forward 1/2" & down 1-1/4" for added passenger comfort. With custom pipes lower than stock, flip the bracket down for a full 3-3/4" lower foot position.

Fits: All '99-'08 Road Star 1600/1700 Models (ex. Warrior)

4560 | Passenger Peg Mounts for Road Star (pr) | \$99.99

Note: Requires Male Mount Pegs, page 98.



MALE MOUNT PEGS

pegs . pegs . pegs .



LIBERATOR™ PEGS

4595	Liberator Pegs, Male Mount (pr)	\$119.99
4597	Liberator Stirrups with Pegs, Male Mount (pr)	\$169.99



ISO®-PEGS

8000	Small ISO-Pegs, Male Mount (pr)	\$44.99
8002	Large ISO-Pegs, Male Mount (pr)	\$45.99
8028	Dually ISO-Pegs, Male Mount (pr) <i>U.S. Patent #Des. 405,393</i>	\$69.99
4450	ISO-Wings (pr)	\$99.99



FLAMIN' PEGS

Patent Pending

4416	Flamin' Pegs, Male Mount (pr)	\$99.99
------	-------------------------------	---------

PILOT™ PEGS

4425	Pilot Pegs, Male Mount (pr)	\$69.99
4430	Mini Pilots, Male Mount (pr)	\$39.99

RETRO PEGS

4400	Retro Pegs, Male Mount (pr)	\$69.99
------	-----------------------------	---------



WIDOW™ PEGS

4491	Widow Pegs, Male Mount (pr)	\$99.99
------	-----------------------------	---------



STILETTO PEGS

4475	Stiletto Pegs, Male Mount (pr)	\$99.99
------	--------------------------------	---------

SWINGWING PEGS

Patent Pending

4466	SwingWing Pegs, Male Mount (pr)	\$159.99
------	---------------------------------	----------



ISO®-SWEPTWING PEGS

4463	ISO-Sweptwing Pegs, Male Mount (pr)	\$89.99
------	-------------------------------------	---------



KAISER PEGS

U.S. Patent # Des. 528,477

4460	Kaiser Pegs, Male Mount (pr)	\$99.99
------	------------------------------	---------



FLAMIN' SWITCHBLADE PEGS

U.S. Patent # 6,893,038

4411	Flamin' Switchblade Pegs, Male Mount (pr)	\$149.99
------	---	----------



ZOMBIE™ PEGS

4470	Zombie Pegs, Male Mount (pr)	\$99.99
------	------------------------------	---------



SWITCHBLADE™ PEGS

U.S. Patent # 6,983,038 & Des. 506,707

4445	Switchblade Pegs, Male Mount (pr)	\$129.99
------	-----------------------------------	----------

pegs